





Modula is a company, specialized in the processing of plastic sheets, capable of manufacturing both single components as well as finished products, always meeting the costumers needs and using the most suitable transformation process.

The company proficiency allows satisfying the even more complicated client's requests and assures the costumers to get finished products, ready for assembling and for selling.

The constant evolution of Modula and its ability to fulfill complex projects in very short times, starting from 3D data, have brought to the collaboration with important industrial groups.





eptagruppo.com

- > Epta Revenues 2013: **112.000.000 Euro**
- > Epta Revenues 2014: **121.000.000 Euro** (Increase 8%)
- > Nr. Epta Employees: **210**
- > Epta Factories Area: **50.000 mq**



IRRIGATION AND WATER  
MANAGEMENT SYSTEMS

[www.idrofoglia.com](http://www.idrofoglia.com)



GENERATING SETS  
AND TOWER LIGHTS

[www.greenpowergen.com](http://www.greenpowergen.com)



LIFTING SYSTEMS

[www.ironsystem.it](http://www.ironsystem.it)



THERMOFORMING  
OF PLASTIC MATERIAL

[www.modulasrl.it](http://www.modulasrl.it)



SUPPLY FOR HOME AND INDUSTRIAL  
FURNITURE AND ACCESSORIES

[www.eptatrade.it](http://www.eptatrade.it)



SERVICE COMPANY FOR  
FOREIGN BUSINESS

[www.eptatrade.it](http://www.eptatrade.it)

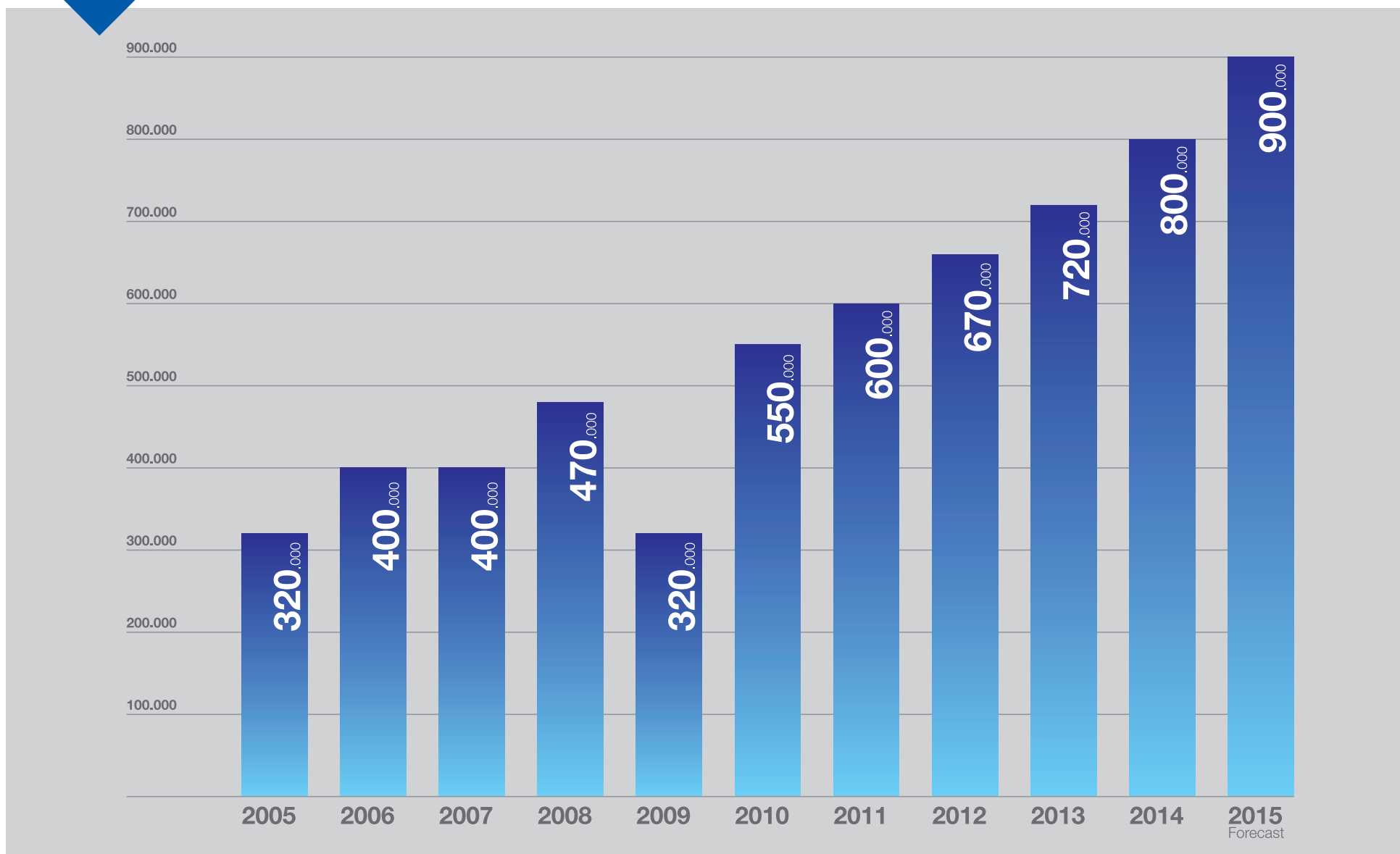



**29%**  
AUTOMOTIVE



**27%**  
COOLING AND  
FREEZING INDUSTRY



**13%**  
INDUSTRIAL AND  
FARMING VEHICLES



**5%**  
BATH DESIGNER FURNITURE  
AND WIDE-RANGE FURNISHING



**19%**  
INDUSTRIAL  
EQUIPMENT



**7%**  
EQUIPMENT FOR  
FITNESS, BEAUTY, MEDICAL AND  
RECREATIONAL FACILITIES

- 1** > Processing of plastic material sheets in many dimensions and shapes.

---
- 2** > Product development and industrialization planning.

---
- 3** > Design and making of thermoforming tools.

---
- 4** > Assembly and processing of single parts and industrial components.

---
- 5** > Personalized packaging, delivery and service.

---
- 6** > Feasibility study for replacement of traditional material for product economies.

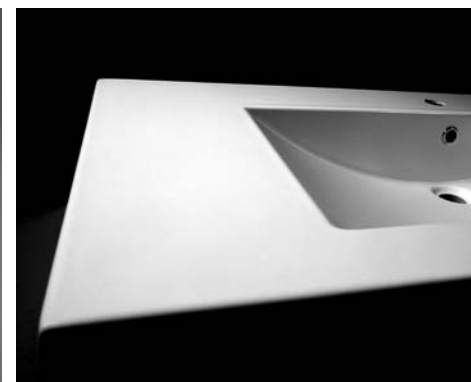
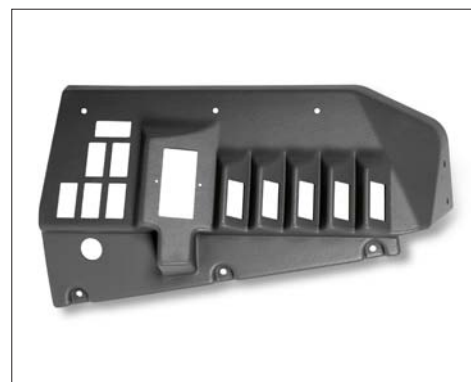
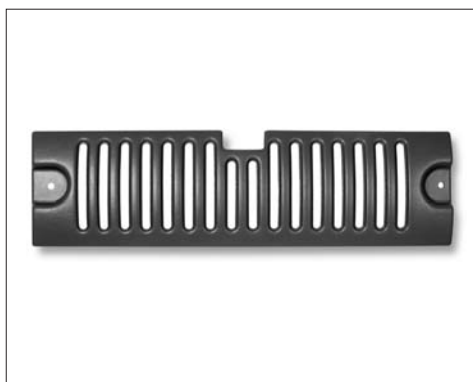





### Certified Quality

Through UNI EN ISO certifications for the supervision of quality standards and environmental protection, Modula assures its customers a more efficient service day after day and, at the same time, cleaves to its commitment of bringing down all critical impacts towards the environment. As a guarantee for our high qualitative standards, designing, manufacturing and customer assistance comply with: the certifications ISO 9001:2008 and ISO 14001:2004. Modula is the innovative and ecologically responsible company that will make your project a reality.



**Audi**

---

**Iveco**

---

**Subaru**

---

**BMW**

---

**Mazda**

---

**Terex**

---

**BredaMenarinibus**

---

**Teuco**

---

**SCM Group**

---

**Prada**

---

**Original Marines**

---

**ISA**

---

**Ariston**

---

- 1** > Experience in wide sectors.
- 2** > Flexibility and design sensitivity.
- 3** > Competitive prices.
- 4** > Own logistical resources (Italy).
- 5** > On time delivery.

- 6** > High level of professionalism of the personnel.
- 7** > Quality and environmental certifications.
- 8** > Planning and industrialization of products.
- 9** > Thermoforming tools management.
- 10** > Research and development of new procedures and materials.

---

|                      |   |  |
|----------------------|---|--|
| GENERAL DIRECTION    | > <b>Massimo Brugnetti</b>  | massimo@modulasrl.it                         |
| EXPORT DEPT.         | > <b>Egidio Barone</b> EXPORT MANAGER<br>> <b>Emanuel Trompke</b> | b.egidio@modulasrl.it<br>export@modulasrl.it |
| DOMESTIC DEPT.       | > <b>Lorenzo Cecchi</b><br>> <b>Lucio Pierotti</b>                | lorenzo@modulasrl.it<br>p.lucio@modulasrl.it |
| PURCHASING DEPT.     | > <b>Marta Paolini</b>  | p.marta@modulasrl.it                         |
| PRODUCTION DEPT.     | > <b>Sara Brugnetti</b>   | commerciale@modulasrl.it                     |
| TECHNICAL DEPT.      | > <b>Mirco Litti</b>  | tecnico@modulasrl.it                         |
| LOGISTIC DEPT.       | > <b>Giorgia Barogi</b>   | marketing@modulasrl.it                       |
| ADMINISTRATION DEPT. | > <b>Marzia Mercatelli</b>  | amministrazione@modulasrl.it                 |

---



**Modula.**  
Perfection of Matter.

**Modula srl**

Loc. Maiano  
61028 Caprazzino di  
Sassocorvaro (PU) - Italy

**phone: +39 0722 700070**

**fax: +39 0722 720017**

**[www.modulasrl.it](http://www.modulasrl.it)**

**[modulasrl@modulasrl.it](mailto:modulasrl@modulasrl.it)**